

IMPORTANT! Read and save these instructions. This manual to be left with the equipment.

2588705_C_EN_2010_UB_IOM

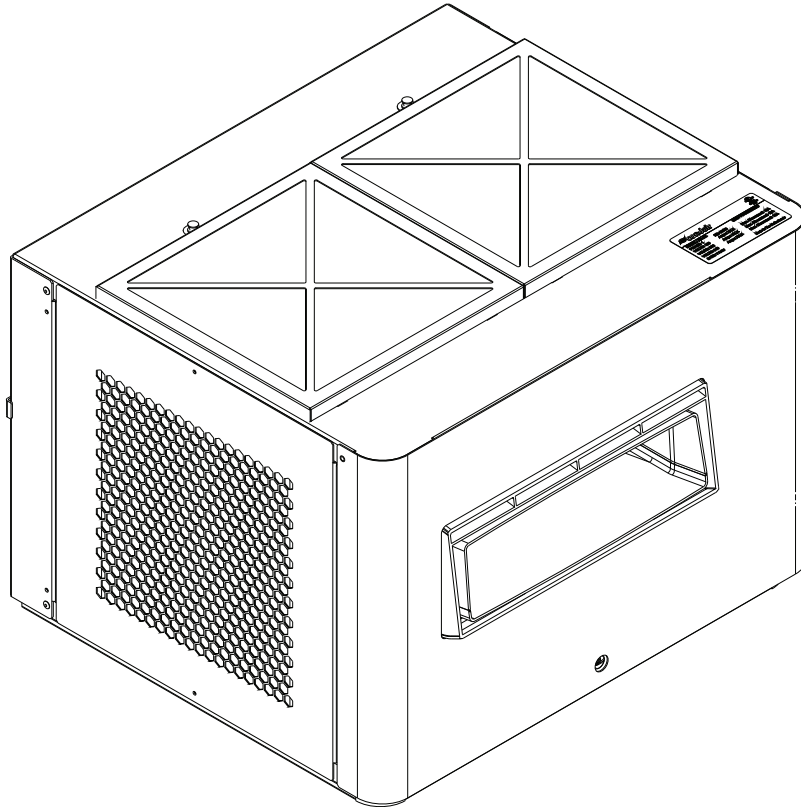

INSTALLATION, OPERATION, AND MAINTENANCE MANUAL

Ultrasonic Blower Pack
US-Series

Thank you for choosing Condair

Installation date (DD / MM / YYYY):

Commissioning date (DD / MM / YYYY):

Site:

Model:

Serial number:

Proprietary Notice

This document and the information disclosed herein are proprietary data of Condair Group AG. Neither this document, nor the information contained herein shall be reproduced, used, or disclosed to others without the written authorization of Condair Group AG, except to the extent required for installation, operation or maintenance of the customer's equipment.

Liability Notice

Condair Group AG does not accept any liability due to incorrect installation, maintenance or operation of the equipment, or due to the use of parts/components/equipment that are not authorized by Condair Group AG.

Copyright Notice

Copyright 2020, Condair Group AG, All rights reserved.

Technical modification rights reserved.

Contents

Contents	3
1 Introduction	5
1.1 Getting Started	5
1.2 General	5
1.2.1 Limitations of the Manual	5
1.2.2 Symbols Used in This Manual	5
1.2.3 Storage of Manual	5
1.2.4 Available Manuals and Languages	6
1.3 Receiving and Storage	6
1.3.1 Inspection	6
1.3.2 Storage, Packaging, and Transportation	6
1.4 Safety Precautions	7
1.5 Compliance	7
2 For Your Safety	8
3 Hygiene	10
3.1 Hygiene Risk Management	10
3.1.1 Guidelines to Keep a Clean System and Prevent Micro-organism Growth	10
3.1.2 Condair Service Offering	11
3.2 Risk Monitoring and Assessment	11
4 Product Description	12
4.1 General Description	12
4.2 Model Designation	12
4.3 Functional Description	13
4.4 Options	14
4.5 Accessories	15
5 Product Specifications	16
5.1 Technical Data	16
5.1.1 Capacity	16
5.1.2 Weights	16
5.1.3 Dimensions	16
6 Specification Drawings	17
7 Installation and Planning	18
7.1 General	18
7.1.1 Installation Overview	19
7.2 Location Requirements	20
7.3 Clearance Requirements	20
7.4 Site Requirements	21
7.4.1 Mounting Requirements	21
7.4.2 Flexible Tube Requirements	21
7.4.3 Power Supply Requirements	22
7.5 Installation	22
7.5.1 Safety	22

7.6	Remote-Mounted Installation	23
7.7	Direct-Mounted Installation	28
8	Operation	33
8.1	General	33
8.2	Starting Up	33
8.3	Shutting Down the Unit	33
9	Maintenance	34
9.1	General	34
9.2	Cleaning and Disinfecting	34
9.2.1	Diluting your Disinfecting Solution (H2O2) to 0.1%	35
9.3	Maintenance List	36
10	Troubleshooting	38
10.1	General Troubleshooting	38
11	Spare Parts List: Ultrasonic Blower	40
12	Commissioning	42
12.1	General	42
12.2	First-time Commissioning	42
13	Decommissioning	43
13.1	General	43
13.2	Removing Unit from Service	43
13.3	Disposing or Recycling the Unit	43
A	Appendix: Installation Checklist	45

1 Introduction

1.1 Getting Started

Thank you for purchasing the Ultrasonic Blower Pack.

The Ultrasonic Blower Pack incorporates the latest technical advances and meets recognized safety standards. Improper use of the Ultrasonic Blower Pack may result in danger to the user or third parties, and/or damage to property.

To ensure safe, proper, and efficient operation of the Ultrasonic Blower Pack, please observe and comply with all information and safety instructions contained in this manual, as well as all relevant documentation of components of the installed humidification system.

If you have additional questions, please contact your Condair representative. They will be glad to assist you.

1.2 General

1.2.1 Limitations of the Manual

The subject of this manual is the Ultrasonic Blower Pack. It is intended as a supplement to the Ultrasonic Humidifier installation, operation and maintenance manuals.

This manual is restricted to the **installation, operation, and maintenance** of the Ultrasonic Blower Pack. This manual is intended for **competent personnel** suitably qualified for their respective tasks. The specifications are supplemented by various separate items of documentation (such as the parts list). Where necessary, appropriate cross-references are made to these publications in the specification.

1.2.2 Symbols Used in This Manual



CAUTION!

The word "CAUTION" in conjunction with the general caution symbol is used to provide safety instructions that, if neglected, may cause damage or malfunction of the unit, or damage to property.



WARNING!

The word "WARNING" in conjunction with the general warning symbol is used to provide safety instructions that, if neglected, may cause injury to personnel. Other specific warning symbols may also be used in place of the general symbol.



Danger!

The word "DANGER" in conjunction with the general danger symbol is used to provide safety instructions that, if neglected, may cause severe injury to personnel or even death. Other specific danger symbols may also be used in place of the general symbol.

1.2.3 Storage of Manual

Keep this manual in a place where it is safe and readily accessible. If the equipment is moved to another location, please ensure that it remains with the equipment.

If the manual is lost or misplaced, please contact Condair for a replacement.

1.2.4 Available Manuals and Languages

Table 1: Document (Part) Numbers and Languages of Available Manuals

	Installation Manual	Operation and Maintenance Manual	Installation, Operation, and Maintenance Manual	Spare Parts List	Engineering Manual
Ultrasonic Humidifier US	2588786_C_EN_2010_US_IM	2588787_B_EN_2010_US_OM	—	2588788_C_EN_2010_US_SPL	—
Ultrasonic Blower Pack UB	—	—	2588705_C_EN_2010_UB_IOM	—	—

1.3 Receiving and Storage

1.3.1 Inspection

After receiving the shipment, inspect the goods as follows:

- Inspect the shipping boxes for damage. Report any shipping box damages to the shipping company without delay.
- Check the goods against the packing slip to ensure that all items have been delivered. Report any shortages to your Condaire representative within 48 hours of receipt of the goods. Condaire does not assume responsibilities for any shortages beyond this period.
- Unpack the parts/components and check for any damage. If parts/components are damaged, notify the shipping company immediately.
- Verify the model type on the specification label to ensure that it is suitable for your installation. Refer to ["Model Designation" on page 12.](#)

1.3.2 Storage, Packaging, and Transportation

Storage

Store the Ultrasonic Blower Pack in its original packaging inside a protected area that meets the following requirements until it is installed, or if it needs to be stored for an extended period of time:

- Room temperature: 41 to 104 °F (5 to 40 °C)
- Room humidity: 10 to 95% RH (non-condensing)

Transportation

For optimum protection always transport the unit and components in their original packaging, and use appropriate lifting/transporting devices (ex. forklift).

Lifting or handling must be carried out by trained and qualified personnel. Ensure that lifting has been fully planned and assessed for possible risks, and that equipment is checked and operated by a skilled operator. It is the customer's responsibility to ensure that operators are fully trained to handle heavy goods and to enforce any applicable lifting regulations.

Packaging

Keep the original packaging of the unit/components for later use.

If the packaging needs to be disposed, observe local regulations on waste disposal. Please recycle packaging where possible.

1.4 Safety Precautions

Regard all safety precautions described in this manual. Refer to ["For Your Safety" on page 8](#).

1.5 Compliance

Follow all local guidelines and regulations regarding the installation and operation of the unit; this includes (and not limited to) mounting, plumbing, water, gas, ventilation, and electrical connections.

Please consult your local Condaire representative to learn more.

2 For Your Safety

General

Every person who is tasked with the installation, operation and/or maintenance of the Ultrasonic Blower Pack must read and understand this manual, as well as any respective installation, operation and/or maintenance manuals before performing any work. Knowing and understanding the contents of these manuals is a basic requirement for protecting personnel against any kind of danger, preventing faulty operation, and operating the unit safely and correctly.

All labels, signs and markings applied to unit must be observed, kept in a readable state, and NOT removed or altered.

Personnel Qualifications

All procedures described in this document must only be performed by personnel who are adequately qualified, familiar with the unit, well trained, and are authorized by the customer.

For safety and warranty reasons, any activity beyond the scope of this manual must only be performed by qualified personnel authorized by Condair.

The unit may not be used by persons (including children) with reduced physical, sensory, or mental abilities, or persons lacking experience and knowledge — unless they are being supervised by a person responsible for their safety, or have received proper instruction on the operation of the system.

All personnel working with the Ultrasonic Blower Pack unit must be familiar with, and comply with the appropriate regulations on workplace safety and prevention of accidents.

Intended Use

The Ultrasonic Blower Pack is intended exclusively for air humidification using Condair-approved within specified operating conditions. Refer to "[Technical Data](#)" on page 16 in for details. Any other type of application, without the express written consent of Condair, is considered to be NOT conforming to its intended purpose, and may lead to dangerous operation and will void the warranty.

In order to operate the equipment in the intended manner all information contained in this manual, in particular the safety instructions, must be observed closely.

Safety Precautions that Must be Observed



DANGER!

Risk of electric shock!

The unit is electrically powered by the humidifier. Using the On/Off switch on the humidifier to shut down the unit will NOT shut off power to the control cabinet. Live parts may be exposed when the access panels or doors are removed. Touching live parts may cause severe injury or even death.

Prevention: The unit must be connected to the humidifier only after all mounting and installation work has been completed and checked for correct workmanship. The humidifier **MUST** be connected from the mains only after work has been completed on the humidifier or blower pack, and the access panels/doors are closed and fastened securely.

Only qualified personnel should perform maintenance or repairs on the unit.

Follow any lockout procedures when servicing the unit.

**DANGER!**

The unit contains moving parts. Putting objects or body parts into the unit can result in serious injury or damage to equipment!

The unit contains rotating parts, such as fans. Putting objects into the fan will affect the proper functioning of the unit, causing damage to the object and the equipment, and will become a safety hazard for people in the vicinity of the unit.

Prevention: Avoid placing objects and body parts into the fan, and if work must be performed, ensure that the unit is properly shut down and electrical power is removed.

**WARNING!**

Risk to Hygiene and Health!

Improper and infrequent maintenance of the unit presents the risk of spreading pathogens (such as bacteria, viruses, and parasites) originating from contaminated water, air, and equipment. Failure to reduce the risks increases the likelihood of causing injuries (requiring medical care), infection, and death.

Prevention: Use, regularly clean, and replace the air and water inlet filters. Regularly flush and disinfect the humidifier, the blower pack, and their components (tanks, hoses, reservoirs, etc.). Use potable, treated water (potable, R.O., or D.I.).

Follow regular maintenance routines as described in "[Maintenance List](#)" on page 36. Follow local regulations.

**WARNING!**

Do NOT leave the unit without power. Risk of contamination.

Do NOT leave the unit unpowered for more than 48 hours, or else a total system disinfect will be required. Without power, the system will not flush properly, resulting in standing water and conditions that may promote the growth of micro-organisms.

Prevention: Leave your unit powered on. If you do not need humidification during the 48 hours, set the humidifier to standby or set the demand to 0.

Preventing Unsafe Operation

All personnel working with the Ultrasonic Blower Pack must immediately report to the customer any alterations or changes to the unit that may affect safety, and **secure the unit against accidental power-up**.

If it is suspected that the unit cannot be operated safely for any of the reasons listed below, shut it down immediately.

Alterations and changes that may affect safe operation include:

- damage to the unit
- loose or damaged electrical connections
- improper operation
- leaks in the distribution system

Modifications to the Unit Prohibited

Modifications are NOT permitted on the Ultrasonic Blower Pack without the express written consent of Condaire.

3 Hygiene

3.1 Hygiene Risk Management

Cold water humidification presents the risk of spreading pathogenic microorganisms into the air. The Ultrasonic Humidifier and Ultrasonic Blower Pack distribute tiny water droplets (mist) that are blown into the space before being absorbed into the air. If the mist was contaminated before leaving the unit and then evaporates, these contaminants are deposited onto surfaces in the space, or are otherwise inhaled or redistributed into the ventilation system.

Pathogens include, and are not limited to, Legionella, E. coli, and viruses, and may originate from contaminated water, air, and equipment.

Regular cleaning and disinfecting is required to optimize humidifier performance and reduce health risks. Follow all safety precautions and local regulations. Refer to ["For Your Safety" on page 8](#).

There are multiple points in the humidification system where a contamination can occur. It is the responsibility of the customer and of Condair to ensure that health hazards due to contamination are reduced to acceptable levels. The use of a hygiene risk assessor is recommended.

Regularly clean and maintain the humidifier and its components, and do NOT miss or ignore the warnings in this manual and service messages displayed on the humidifier.

Supply Air and Water

Pathogens can originate from the water supply, such as a tank or water line. It is important that standing water in the tank or in the water line is flushed frequently to prevent the buildup of contaminants, and the water is filtered and treated.

Pathogens may also enter the humidification system through the ventilation system or from within the humidifier space.

A fan blows air out of the water reservoir into flexible tubes, and further into a blower pack and into the atmosphere. Contaminated air can join the mist, so it is recommended to use air filters in the ventilation system, in the humidifier, and in the Ultrasonic Blower Pack. Ensure to use the supplied air filters at all times and replace them regularly (as recommended in the Ultrasonic Humidifier Maintenance and Operation Manual).

3.1.1 Guidelines to Keep a Clean System and Prevent Micro-organism Growth

- Perform a risk assessment of the water system using a competent person, and implement an appropriate monitoring and control program.
- Connect a RO system to a clean, potable main water supply.
- Ensure that the system is cleaned and/or flushed regularly.
- Ensure that the buffer tank is clean and sterile before use.
- Enter a service contract that suits the needs of the company.
- Stop the system if polluted drinking water is found in the area.
- Avoid water temperatures above 68 °F (20 °C). Temperatures between 20-60 °C (68-140 °F) favor the growth of Legionella.
- Do not stop the system unless it is faulty or leaking (to avoid water stagnation).
- If the power to the system is interrupted (such that the unit fails to flush or drain) for more than 48 hours, complete a total system disinfection.
- Refrain from closing sections of the system, unless there is a leakage or fault (to avoid water stagnation).
- Disinfect at least once per year, and after every maintenance or repair.
- Analyze the water and test for harmful bacteria at least once per year.
- Conduct follow-up measurements until the system is clean if bacteria has been detected in the system.

3.1.2 Condair Service Offering

The Condair service team can help with expert technicians who can provide:

- Bacteriological troubleshooting on-site*.
- Cleaning and disinfecting.
- Preventative maintenance.
- Repair and fault finding.
- Training and guidance.

Note: * Condair uses a quick method for measuring bacterial activity in the water with the use of BactiQuant (BQ). Once the water sample has been taken, the bacteriological quality of the water is read within 30 minutes, and the Condair service team will disinfect the system if necessary.

Please contact your local Condair representative for further information about our services.

3.2 Risk Monitoring and Assessment

Water hygiene assessments must be performed at the site to determine the risk and severity of hygiene hazards that affect the health and safety of the public. Performing a risk assessment with regular monitoring will allow procedures to be adjusted.

Ensure that the person conducting the assessment is qualified.

A typical assessment inspects the following:

- Supply water quality. Refer to ["Technical Data" on page 16](#).
- Environment around the humidifier.
- Maintenance procedures. Refer to ["Maintenance List" on page 36](#).
- Water pre-treatment options (such as using UV light, using reverse osmosis or deionized water, etc.).

Proper maintenance procedures along with recommended site controls will help ensure compliance to local regulations and protect the public.

It is recommended to monitor the humidification system weekly, and then monthly once satisfactory levels are maintained.

Ensure that the results of every assessment is recorded.

IMPORTANT! Failure to make adequate provision against the outbreak of disease, such as Legionnaires' disease, may cause fatalities, illness, and liabilities.

4 Product Description

4.1 General Description

The Ultrasonic Blower Pack is used along with an atmospheric mist generating humidifier to distribute very fine water droplets directly into local areas or into spaces that do not have a built-in air distribution system. The Ultrasonic Blower Pack must be mounted directly on the Ultrasonic Humidifier, or remotely mounted on suitable surfaces in the space. Large ultrasonic humidifiers, with capacities 18 kg/h (40 lb/h) use two Ultrasonic Blower Pack units. Refer to [Figure 1 below](#).

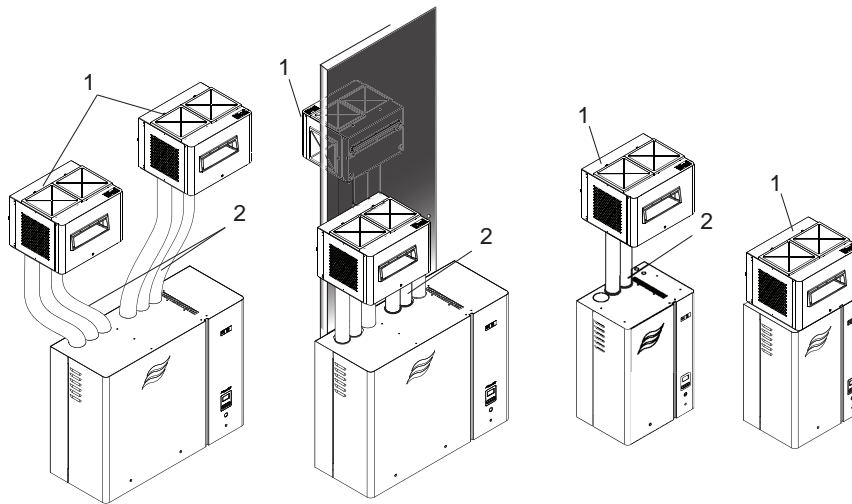

Figure 1 - Ultrasonic Blower Pack Typical Remote and Direct Mounted Installations

1. Ultrasonic Blower Pack
2. Flexible tube

4.2 Model Designation

The specification label on the top face of the Ultrasonic Blower Pack shows its model type, serial number, manufacturing date, and electrical rating.

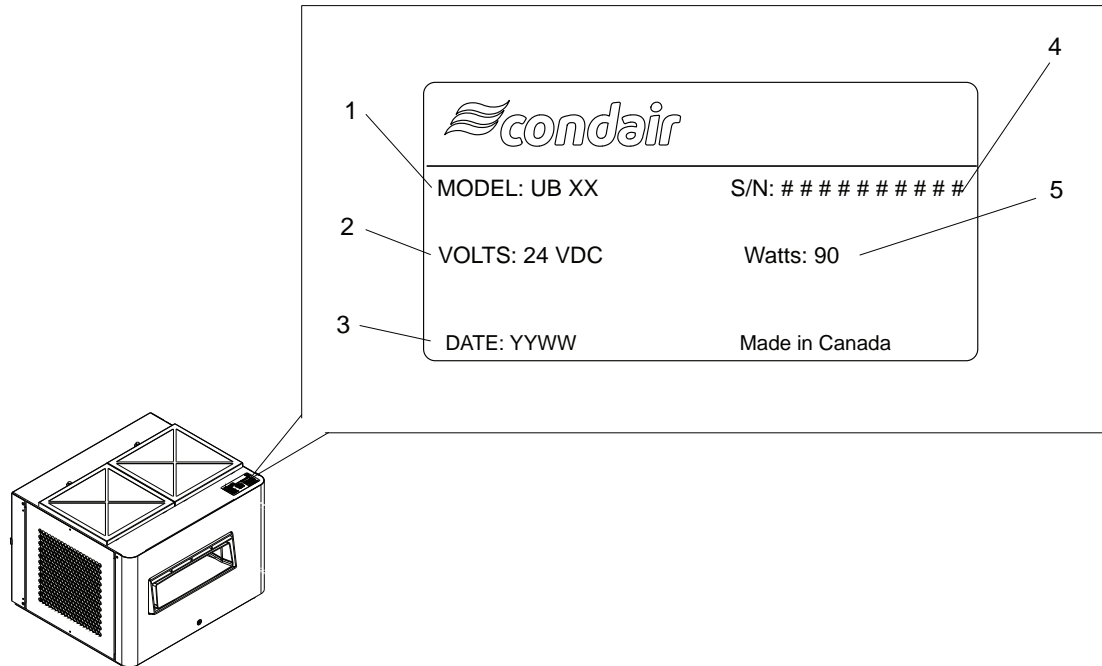

Figure 2 - Ultrasonic Blower Pack Specification Label

1. Model
2. Voltage
3. Date of manufacture
4. Serial Number
5. Wattage

4.3 Functional Description

The Ultrasonic Blower Pack consists of:

- metal housing
- electric cable (to connect to the humidifier)
- two 24 VDC fans (one top fan and one bottom fan)
- an optional air filter kit (comes with 4 metal-framed filters)
- a pressurized box
- a mist channel

When the Ultrasonic Humidifier is powered on, the safety relay closes and permits the humidifier to generate mist when it receives a demand signal. The Ultrasonic Blower Pack is controlled through the control board of the Ultrasonic Humidifier and receives an ON or OFF signal. The mist is generated in the ultrasonic humidifier and travels through the connection tubes to the blower pack. From there, the mist travels through the blower pack's mist channel and is discharged through the front of the blower pack. The exiting mist is propelled into the space by the air blown out from the pressurized box. The turbulent air causes mixing and quick absorption between the blown out air and mist streams.

Blower pack fans provide feedback to the ultrasonic humidifier through the connection cable. This feedback allows the humidifier to cease mist generation when a blower pack fan fails. This allows the entire system to shut down safely and avoids wetting in the space. A warning message "Blower pack not connected" will display on the humidifier LCD display.

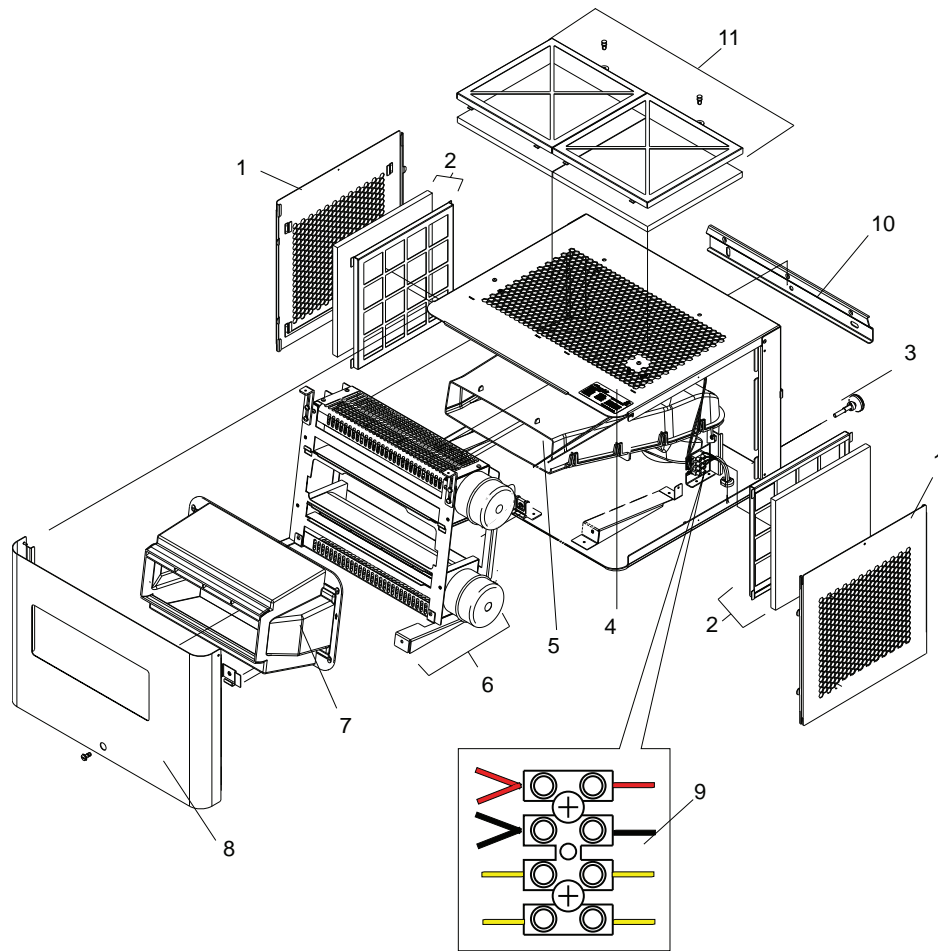

Figure 3 - Ultrasonic Blower Pack Components

1. Side panel
2. Foam filter and frame, side, assembly (optional)
3. Adjustable leg (to level the units that are remote-mounted)
4. Specification label (see "Model Designation" on page 12)
5. Mist channel
6. Fan assembly
7. Pressurized box
8. Front panel
9. Terminal block
10. Wall mount bracket (for remote installation)
11. * Foam filter and frame, assembly (optional), top

4.4 Options

Options for the Ultrasonic Blower Pack:

- Air filter assembly
 - » (PN: 2588764)
- Flexible Tubes.
 - » (PN: 2594413 flexible tube for remote mount)
 - » (PN: 2594409 flexible tube for direct mount)

4.5 Accessories

Accessories for the Ultrasonic Blower Pack:

- Wall mounting brackets (supplied) to mount the unit remotely.
- *Ultrasonic Blower Pack Installation, Operation, and Maintenance Manual* (P/N: 2588705_C_EN_2010_UB_IOM) (supplied).

5 Product Specifications

5.1 Technical Data

5.1.1 Capacity

Table 2: Ultrasonic Blower Pack Capacity

Model	Capacity	
UB 7	3 kg/h (6.6 lb/h)	90 W
UB 13	6 kg/h (13.2 lb/h)	90 W
UB 20	9 kg/h (19.8 lb/h)	90 W

Note: The large Ultrasonic Humidifier, US 40, is equipped with dual stainless steel reservoirs – each with its own dedicated driver board. The large unit must be equipped with two Ultrasonic Blower Packs.

5.1.2 Weights

Table 3: Ultrasonic Blower Pack Packaged Weight

Model	Weight
Ultrasonic Blower Pack (all models)	17.7 kg (39 lb)

5.1.3 Dimensions

Table 4: Ultrasonic Blower Pack Dimensions

Model	Dimensions height x width x depth
Ultrasonic Blower Pack (all models)	371 x 544 x 432 mm (14.6 x 21.4 x 17.0 in)

6 Specification Drawings

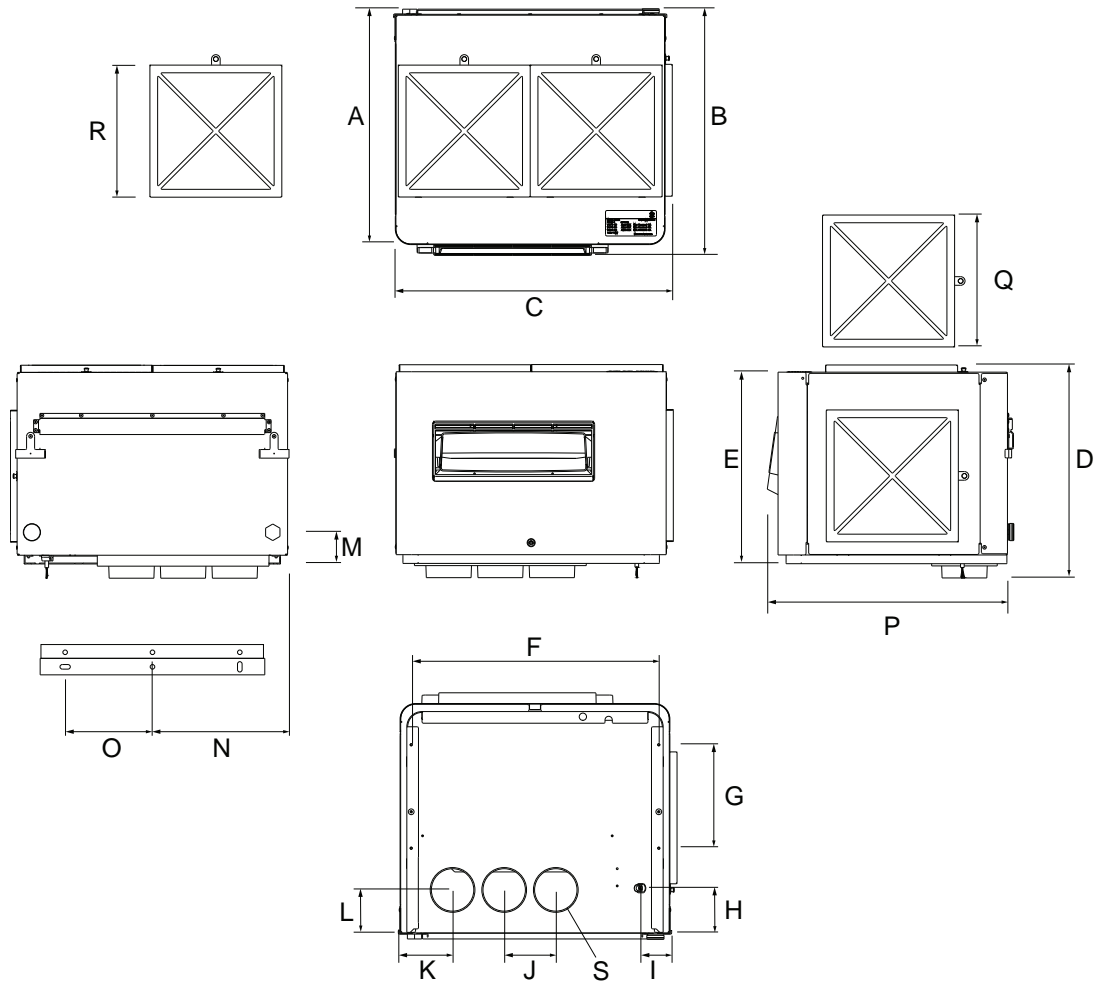

Figure 4 - Ultrasonic Blower Pack Overall Dimensions in millimeters and (inches)

A. 409 (16.1)	K. 92 (3.6)
B. 428 (16.8)	L. 78 (3.1)
C. 544 (21.4)	M. 55 (2.2)
D. 375 (14.8)	N. 235 (9.3)
E. 339 (13.3)	O. 148 (5.8)
F. 432 (17)	P. 417 (16.4)
G. 180 (7.1)	Q. 228 (9)
H. 80 (3.1)	R. 228 (9)
I. 48 (1.9)	S. Inner Diameter 74 (2.9); Outer Diameter 78 (3.1)
J. 90 (3.5)	

7 Installation and Planning

7.1 General

Strictly observe and perform all installation tasks including the mounting of the unit and connection of the water and power supplies as described in this manual. Observe and comply with all local and national codes dealing with water and electrical installations. Condaire does not accept any liability for installation of humidification or dehumidification equipment by unqualified personnel, or the use of equipment and parts that are not authorized by Condaire.

Personnel Qualifications

All installation work must be performed only by licensed personnel authorized by the customer. It is the customer's responsibility to verify qualifications of the personnel.

Safety

Observe the following safety precautions:



DANGER!

Risk of electric shock!

The unit is electrically powered by the humidifier. Using the On/Off switch on the humidifier to shut down the unit will NOT shut off power to the control cabinet. Live parts may be exposed when the access panels or doors are removed. Touching live parts may cause severe injury or even death.

Prevention: The unit must be connected to the humidifier only after all mounting and installation work has been completed and checked for correct workmanship. The humidifier MUST be connected from the mains only after work has been completed on the humidifier or blower pack, and the access panels/doors are closed and fastened securely.

Only qualified personnel should perform maintenance or repairs on the unit.

Follow any lockout procedures when servicing the unit.



DANGER!

The unit contains moving parts. Putting objects or body parts into the unit can result in serious injury or damage to equipment!

The unit contains rotating parts, such as fans. Putting objects into the fan will affect the proper functioning of the unit, causing damage to the object and the equipment, and will become a safety hazard for people in the vicinity of the unit.

Prevention: Avoid placing objects and body parts into the fan, and if work must be performed, ensure that the unit is properly shut down and electrical power is removed.



WARNING!

Risk to Hygiene and Health!

Improper and infrequent maintenance of the unit presents the risk of spreading pathogens (such as bacteria, viruses, and parasites) originating from contaminated water, air, and equipment. Failure to reduce the risks increases the likelihood of causing injuries (requiring medical care), infection, and death.

Prevention: Use, regularly clean, and replace the air and water inlet filters. Regularly flush and disinfect the humidifier, the blower pack, and their components (tanks, hoses, reservoirs, etc.). Use potable, treated water (potable, R.O., or D.I.).

Follow regular maintenance routines as described in "[Maintenance List](#)" on page 36. Follow local regulations.



WARNING!

Do NOT leave the unit without power. Risk of contamination.

Do NOT leave the unit unpowered for more than 48 hours, or else a total system disinfect will be required. Without power, the system will not flush properly, resulting in standing water and conditions that may promote the growth of micro-organisms.

Prevention: Leave your unit powered on. If you do not need humidification during the 48 hours, set the humidifier to standby or set the demand to 0.

7.1.1 Installation Overview

The Ultrasonic Blower Pack can be installed remotely with any Ultrasonic Humidifier, or mounted directly onto the Ultrasonic Humidifier (large units excluded -- the **Ultrasonic Blower Pack can only be installed remotely on large Ultrasonic Humidifiers**). Direct-mounting is currently unavailable for large Ultrasonic Humidifiers. [Figure 5 below](#) shows typical mounting configurations of the Ultrasonic Blower Pack and humidifier. Learn how to install the unit in "[Installation](#)" on page 22.

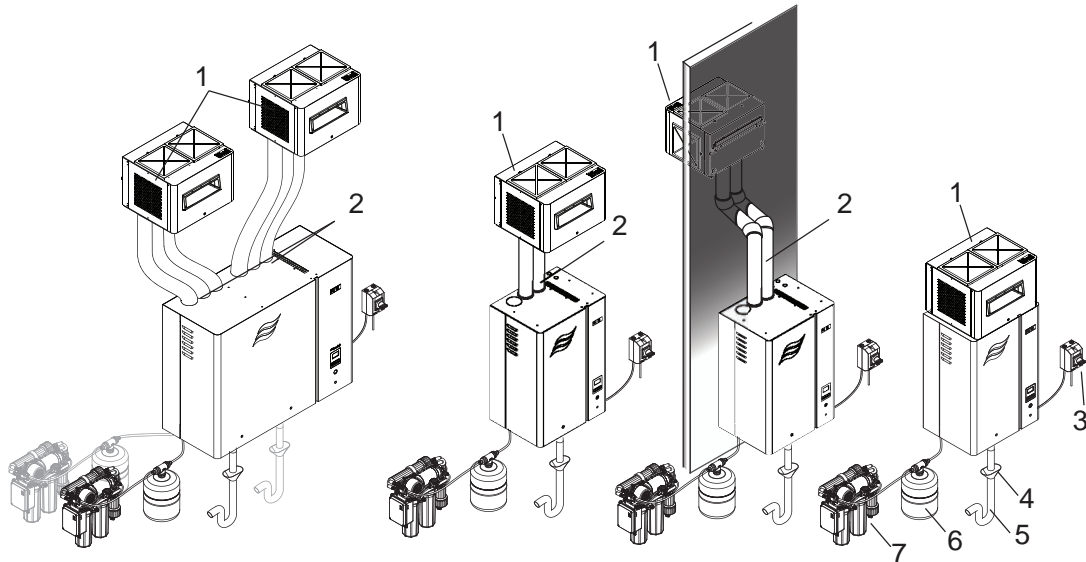

Figure 5 - Ultrasonic Blower Pack Typical Installation with the Humidifier (Medium Humidifier Shown)

1. Ultrasonic Blower Pack
2. Flexible tubes
3. Electrical disconnect
4. Air gap funnel (for drain line)
5. Trap
6. Expansion tank (optional)
7. R.O. system

Note: The drain line should have a minimum internal diameter of 22 mm (7/8 in), with a constant downslope (minimum 1.2°) to the air gap funnel, and must not touch the sides or bottom of the funnel. Use stainless steel or plastic pipe if using D.I. or R.O. water.

Note: Flexible tubes should be as short as possible – the maximum length varies depending on the humidifier capacity and material used (refer to "[Model Designation](#)" on page 12). The flexible tube must have a constant slope (minimum incline of 10° or minimum decline of 2°), and have no restrictions in the line, and be no longer than 2 m in equivalent length (ex. bends in the tubing affect the equivalent length).

Note: Flexible tubes must not merge. Merging multiple tubes to supply an individual blower pack will lead to water droplets forming inside the mist channel and the risk of spitting out, wetting the floor in front of the unit, any adjacent equipment, and walls. If a humidifier capacity higher than 9 kg/h (19.8 lb/h) is needed, use a separate Ultrasonic Blower Pack (one for each 9 kg/h (19.8 lb/h) required).

7.2 Location Requirements

The installation of the Ultrasonic Blower Pack depends largely on the location of the Ultrasonic Humidifier.

For medium size Ultrasonic Humidifiers, the Ultrasonic Blower Pack may be mounted directly on the unit, or it may be installed remotely. For large size Ultrasonic Humidifiers, the Ultrasonic Blower Pack may only be installed remotely and connected by flexible tubes. To reduce condensate losses in remote installations, Condaire recommends installing the Ultrasonic Blower Pack as close to the humidifier as possible. Distances longer than an equivalent straight-length of 2 m (6.6 ft) reduces the mist output drastically. Refer to ["Mounting Requirements" on the facing page](#).

Refer to the *Ultrasonic Humidifier Installation Manual* (P/N: 2588786_C_EN_2010_US_IM).

The clearance requirements ensure that mist does not come into contact with any surfaces before it is absorbed into the air. Refer to ["Clearance Requirements" below](#).

IMPORTANT! For installations where the humidified space is separate from the humidifier, ensure that there is adequate air flow to the humidifier, and adequate air flow out of the space to be humidified, such that **the atmospheric pressure in these spaces are equal**. For example, if the humidifier is in a separate room from the Ultrasonic Blower Pack, provide air from the humidified space to the air intake of the humidifier.

7.3 Clearance Requirements

The clearances for the Ultrasonic Blower Pack in [Figure 6 below](#) and in [Table 5 on the facing page](#) are shown for reference only, and are the minimums required for the proper functioning of the equipment. Consult local and national installation codes. Condaire does not accept responsibility for violations of installation codes.

Adjacent Ultrasonic Blower Pack units should be separated by distance, D. For clearance requirements for the Ultrasonic Humidifier, consult the *Ultrasonic Humidifier Installation Manual* (P/N: 2588786_C_EN_2010_US_IM).

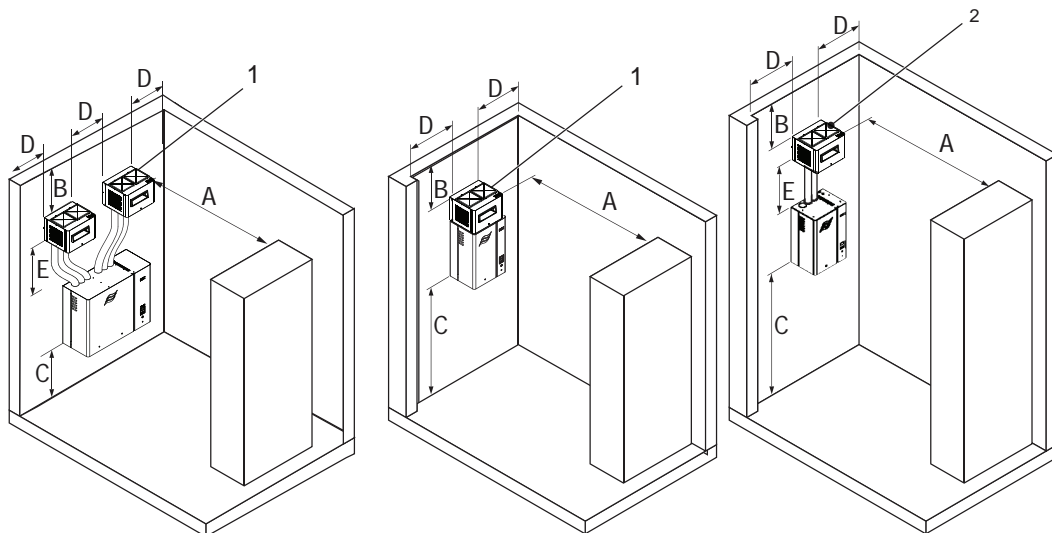

Figure 6 - Ultrasonic Blower Pack Clearance Suggestions

1. Direct-mounted blower pack
2. Remote-mounted blower pack

Table 5: Clearances for the Ultrasonic Blower Pack

Dimensions	US 7, 13, 20 (medium housing)	US 40 (large housing)
A	3.7 m (12 ft)	3.7 m (12 ft)
B	0.5 m (1.5 ft)	0.5 m (1.5 ft)
C	1 m (3.3 ft)	1 m (3.3 ft)
D	0.8 m (2.5 ft)	0.8 m (2.5 ft)
E*	2 m (7 ft)	2 m (7 ft)

The minimum clearances are based on nominal conditions of 22 °C (72 °F) at 30% RH, for the US 20 unit.

* Maximum equivalent straight length of flexible tubes.

7.4 Site Requirements

Prepare the Ultrasonic Blower Pack for installation by ensuring the following site requirements are satisfied. Report any discrepancies to your Condaire representative.

Ensure that the installation of the Ultrasonic Blower Pack is compliant with all applicable local regulations and codes.

7.4.1 Mounting Requirements

- The selected location for the humidifier and blower pack should meet the requirements described in ["Location Requirements" on the previous page](#) and ["Clearance Requirements" on the previous page](#).
- The Ultrasonic Blower Pack is designed for wall-mounting in protected interiors. The mounting surface (wall, pillar, etc.) for the Ultrasonic Blower Pack and humidifier must offer a sufficiently high load-bearing capacity, and be suitable for the installation. Refer to ["Technical Data" on page 16](#).
- The Ultrasonic Blower Pack must be level.
- The Ultrasonic Blower Pack must only be installed and operated in a drip-proof location within buildings, where the permissible ambient temperature and humidity conditions are maintained. Refer to ["Technical Data" on page 16](#) for details.
- The Ultrasonic Blower Pack should not be mounted on hot or very cold surfaces, near vibrating components, or on the floor.
- The Ultrasonic Blower Pack should not be used as a ducted blower. The air volume from the Ultrasonic Blower Pack is not sufficient for proper operation in a ducted system.

7.4.2 Flexible Tube Requirements

- An optional kit is available (see Ultrasonic Humidifier Spare Parts List) that contains a 2 m (78 in) flexible tube.
- The length of flexible tubes must be kept as short as possible. Exceeding an equivalent length of 2 m (3.3 ft) will adversely affect the performance of the unit and void the warranty.
- Maintain a constant inner diameter of 80 mm (3.15 in) within the connection.
- Flexible tubes should allow condensate to flow back to the humidifier (otherwise, use condensate traps for drainage along the connection).
- Connections must be tight.
- Avoid sharp bends in the connection. The suggested **maximum bend should not exceed 30°**.
- Avoid horizontal sections in the connection to reduce standing water and inhibit organic growth in the humidifier and distribution system.
- Avoid merging flexible tubes.

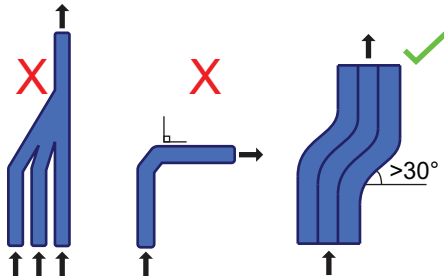

Figure 7 - Avoid horizontal sections and merging flexible tubes

7.4.3 Power Supply Requirements

- The Ultrasonic Blower Pack is powered by the humidifier; 90 W at 24 VDC. The power requirements are indicated on the specification label on the top face of the unit. Refer to ["Model Designation"](#) on page 12.

7.5 Installation

The Ultrasonic Blower Pack can be installed directly onto a medium sized Ultrasonic Humidifier, and can be installed remotely for any Ultrasonic Humidifier.

- To learn how to mount the unit remotely, refer to ["Remote-Mounted Installation"](#) on the facing page.
- To learn how to mount the unit directly (on a medium humidifier), refer to ["Direct-Mounted Installation"](#) on page 28.

7.5.1 Safety

Observe all safety precautions and comply with local installation codes. Refer to ["For Your Safety"](#) on page 8.

7.6 Remote-Mounted Installation

The electrical installation work requires removal of the covers on the Ultrasonic Blower Pack and door panels of the humidifier.

Before proceeding with the installation, Condaair recommends that you familiarize yourself with flexible tube installation on the humidifier. Refer to the Ultrasonic Humidifier Installation Manual.

Please observe the following:

- All electrical installation work must be performed only by skilled and qualified technical personnel (e.g. electrician with appropriate training) authorized by the customer. It is the customer's responsibility to verify qualification of the personnel.
- The electrical installation must be performed according to the wiring diagrams in the humidifier manual and this manual, the instructions in this section, as well as applicable local and national regulations.
- Make sure that the available voltage and phase of the power supply match the requirements for the blower pack, as indicated on the specification label. Refer to "[Model Designation](#)" on page 12.
- All cables must lead into the unit through appropriate cable feed-throughs and must be secured with clamp straps.
- Cables must be secured with tie wraps (supplied) to prevent rubbing on any components, or become a tripping hazard.
- Observe local and national codes for maximum cable length and required wire sizes for cables.

Please note the following warnings:



DANGER!

Risk of electric shock!

The unit is electrically powered by the humidifier. Using the On/Off switch on the humidifier to shut down the unit will NOT shut off power to the control cabinet. Live parts may be exposed when the access panels or doors are removed. Touching live parts may cause severe injury or even death.

Prevention: The unit must be connected to the humidifier only after all mounting and installation work has been completed and checked for correct workmanship. The humidifier **MUST** be connected from the mains only after work has been completed on the humidifier or blower pack, and the access panels/doors are closed and fastened securely.

Only qualified personnel should perform maintenance or repairs on the unit.

Follow any lockout procedures when servicing the unit.



CAUTION!

Electrostatic discharge (ESD)!

The electronic components inside the control cabinet in the humidifier are sensitive to electrostatic discharge (ESD).

Prevention: Take appropriate measures to protect the electronic components inside the unit against damage caused by electrostatic discharge (ESD). Refer to ANSI/ESD-S20.20.



DANGER

Risk of electric shock!

Touching live parts may cause severe injury or even death.

Prevention: DO NOT plug the unit into a wall outlet until all installation work has been completed and checked.

1. Mount the Ultrasonic Blower Pack. Refer to ["Location Requirements" on page 20](#) and ["Clearance Requirements" on page 20](#).
 - a. Locate a 2×4 wooden stud or equivalent support in the mounting surface, and mark the position with the help of a level – refer to [Figure 8 on the facing page](#).
 - b. Install the wall bracket to the wall with mounting screws strong enough to support the weight of the Ultrasonic Blower Pack. Refer to ["Technical Data" on page 16](#).
 - c. Rotate the interlocks on the side of the unit outwards to unlock them.
 - d. Lower the Ultrasonic Blower Pack onto the wall bracket.
 - e. Twist the adjustable legs to adjust their lengths and ensure that the Ultrasonic Blower Pack is level.
 - f. Return the interlocks to their locked position.

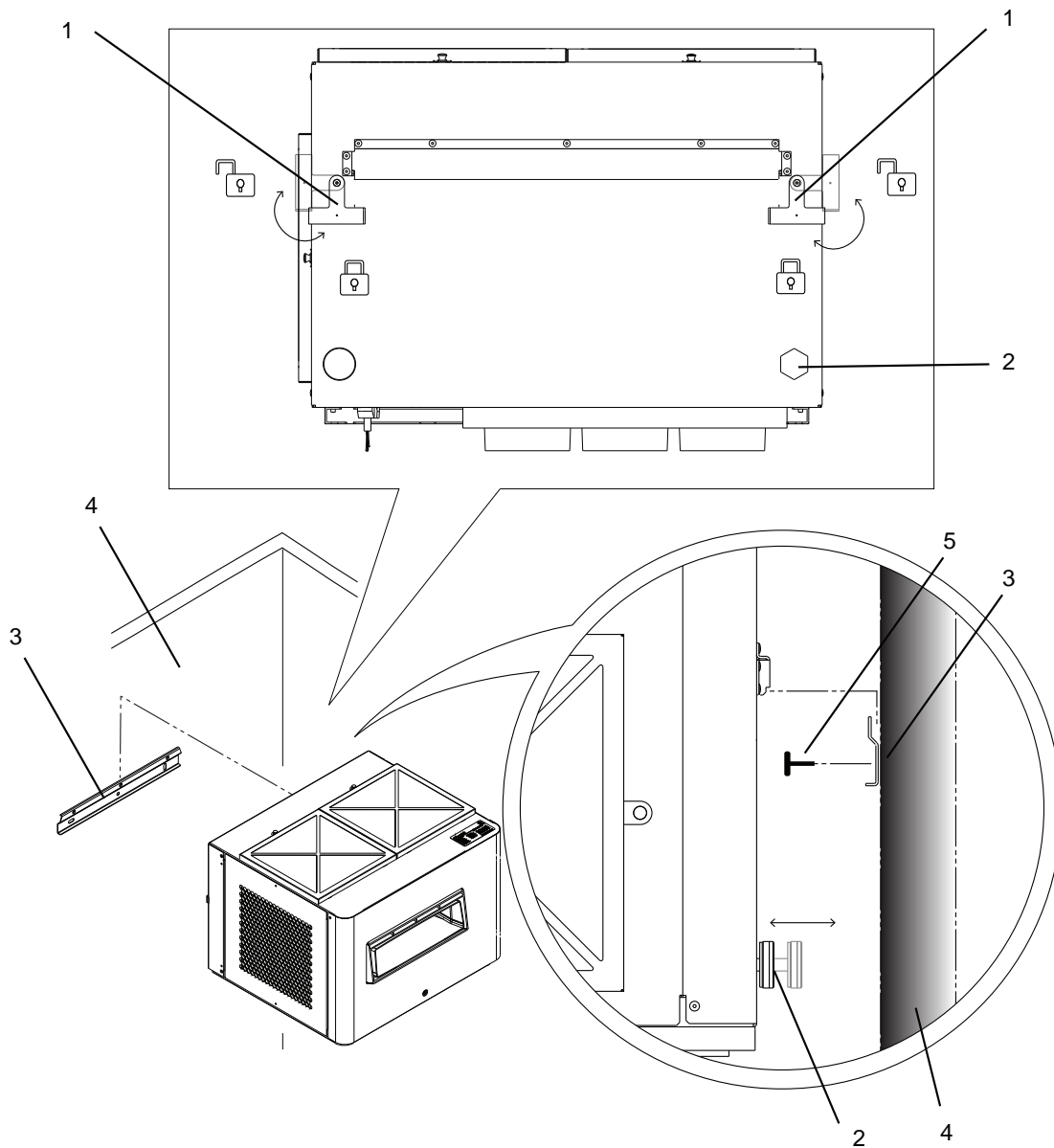

Figure 8 - Remote Mounting the Ultrasonic Blower Pack

1. Interlock (supplied)
2. Adjustable Leg (supplied)
3. Wall Bracket (supplied)
4. Wall
5. Mounting Screw (supplied)

2. Connect the flexible tubes. Refer to "[Flexible Tube Requirements](#)" on page 21.

IMPORTANT! Use gloves and keep the system clean during installation.

- a. Remove the clamp from the flexible tube. This will allow the flexible tube to pass through the top of the humidifier cabinet.

- b. Route the 'connector' end (item 3) of the flexible tube to the top of the water reservoir. Secure the connection by gently inserting the connector and tube into the reservoir, as seen in [Figure 9 below](#).
If the Ultrasonic Blower Pack is directly mounted on the humidifier, the mist channel connection extends through the top of the humidifier, into the plumbing cabinet.
- c. Route the 'clamp' end (item 1) of the flexible tube through the top of the humidifier.
- d. Place the 'clamp' end (item 1) of the flexible tube over the base of the mist channel in the Ultrasonic Blower Pack. Ensure that there are no horizontal sections in the tube, then secure the connection by using clamps.
- e. Test the unit and check for leaks once installation is complete.

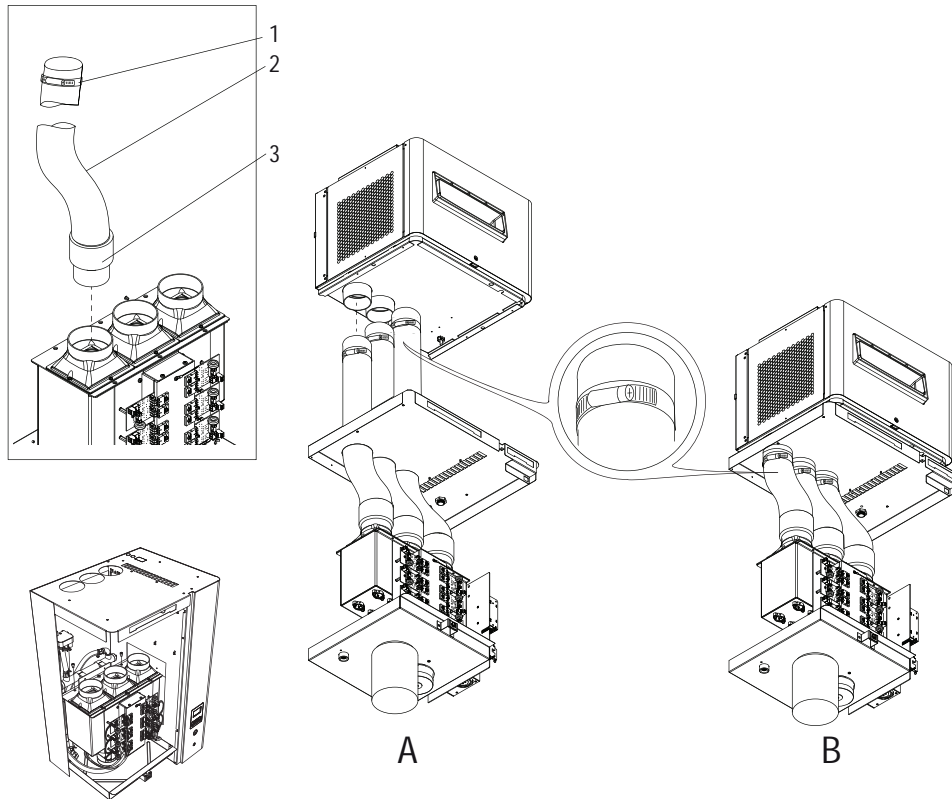

Figure 9 - Flexible Tubes. (A) Remote-Mount Installation. (B) Direct-Mount Installation.

1. Clamp
2. Flexible tube
3. Connector

3. Connect the power supply and security loop cables.
 - a. (If applicable) Plug the power and security loop cables into the back of the Ultrasonic Blower Pack. The unit should be shipped with these wires already installed to the terminal block.

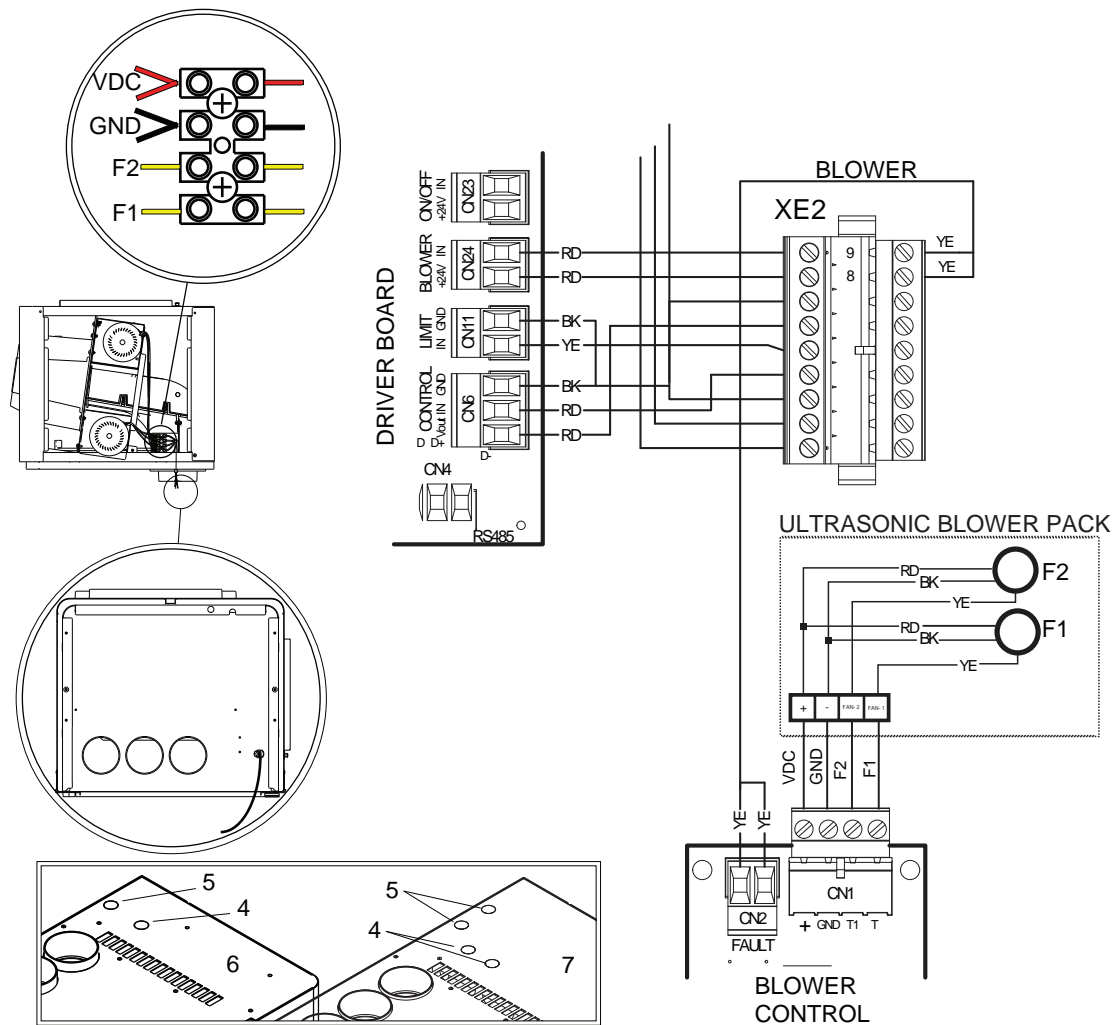

Figure 10 - Power and Security Loop Cables

1. Control cabinet
2. External
3. Driver board
4. Knockout for Ultrasonic Blower Pack wires
5. Knockout for control devices
6. Medium Ultrasonic Humidifier
7. Large Ultrasonic Humidifier

- b. Punch the knockout hole on the top of the Ultrasonic Humidifier.
 - c. Install the grommet in the knockout hole and route the cables through the grommet.

Note: Grommets are required for remote installations.
 - d. Remove the door panel on the humidifier control cabinet.
 - e. Run the security loop and power cables along the cable chase and lead the cables inside the humidifier's electrical cabinet.
 - f. Insert the cables into the screw-type connector on the control board. Tighten the screws and ensure that the wires are properly in place.
 - g. Install and fasten the door panel on the humidifier control cabinet.
4. Perform the checks described in ["Installation Checklist" on page 45.](#)

7.7 Direct-Mounted Installation

The electrical installation work requires removal of the covers on the Ultrasonic Blower Pack and door panels of the humidifier.

Before proceeding with the installation, Condaair recommends that you familiarize yourself with flexible tube installation on the humidifier. Refer to the Ultrasonic Humidifier Installation Manual.

Please observe the following:

- All electrical installation work must be performed only by skilled and qualified technical personnel (e.g. electrician with appropriate training) authorized by the customer. It is the customer's responsibility to verify qualification of the personnel.
- The electrical installation must be performed according to the wiring diagrams in the humidifier manual and this manual, the instructions in this section, as well as applicable local and national regulations.
- Make sure that the available voltage and phase of the power supply match the requirements for the blower pack, as indicated on the specification label. Refer to "[Model Designation](#)" on page 12.
- All cables must lead into the unit through appropriate cable feed-throughs and must be secured with clamp straps.
- Cables must be secured with tie wraps (supplied) to prevent rubbing on any components, or become a tripping hazard.
- Observe local and national codes for maximum cable length and required wire sizes for cables.

Please note the following warnings:



DANGER!

Risk of electric shock!

The unit is electrically powered by the humidifier. Using the On/Off switch on the humidifier to shut down the unit will NOT shut off power to the control cabinet. Live parts may be exposed when the access panels or doors are removed. Touching live parts may cause severe injury or even death.

Prevention: The unit must be connected to the humidifier only after all mounting and installation work has been completed and checked for correct workmanship. The humidifier **MUST** be connected from the mains only after work has been completed on the humidifier or blower pack, and the access panels/doors are closed and fastened securely.

Only qualified personnel should perform maintenance or repairs on the unit.

Follow any lockout procedures when servicing the unit.



CAUTION!

Electrostatic discharge (ESD)!

The electronic components inside the control cabinet in the humidifier are sensitive to electrostatic discharge (ESD).

Prevention: Take appropriate measures to protect the electronic components inside the unit against damage caused by electrostatic discharge (ESD). Refer to ANSI/ESD-S20.20.



DANGER

Risk of electric shock!

Touching live parts may cause severe injury or even death.

Prevention: DO NOT plug the unit into a wall outlet until all installation work has been completed and checked.

IMPORTANT! The Ultrasonic Blower Pack CANNOT be direct-mounted on the large Ultrasonic Humidifier. For Ultrasonic Blower Pack installations with large units, remotely mount the Ultrasonic Blower Pack.

1. Punch the knockouts at the top of the humidifier and open the front door panel on the humidifier.
2. Connect the power supply and security loop cables.
 - a. Route the power and security loop cables through the knockout hole.
 - b. Place the unit on the humidifier.
 - i. Avoid pinching the cables when placing the unit on the humidifier.
 - ii. Align the mist channel with the openings at the top of the humidifier.
 - c. Open the door panel on the humidifier control cabinet.
 - d. Wire and connect the power supply and security loop cables to the driver board inside the humidifier.

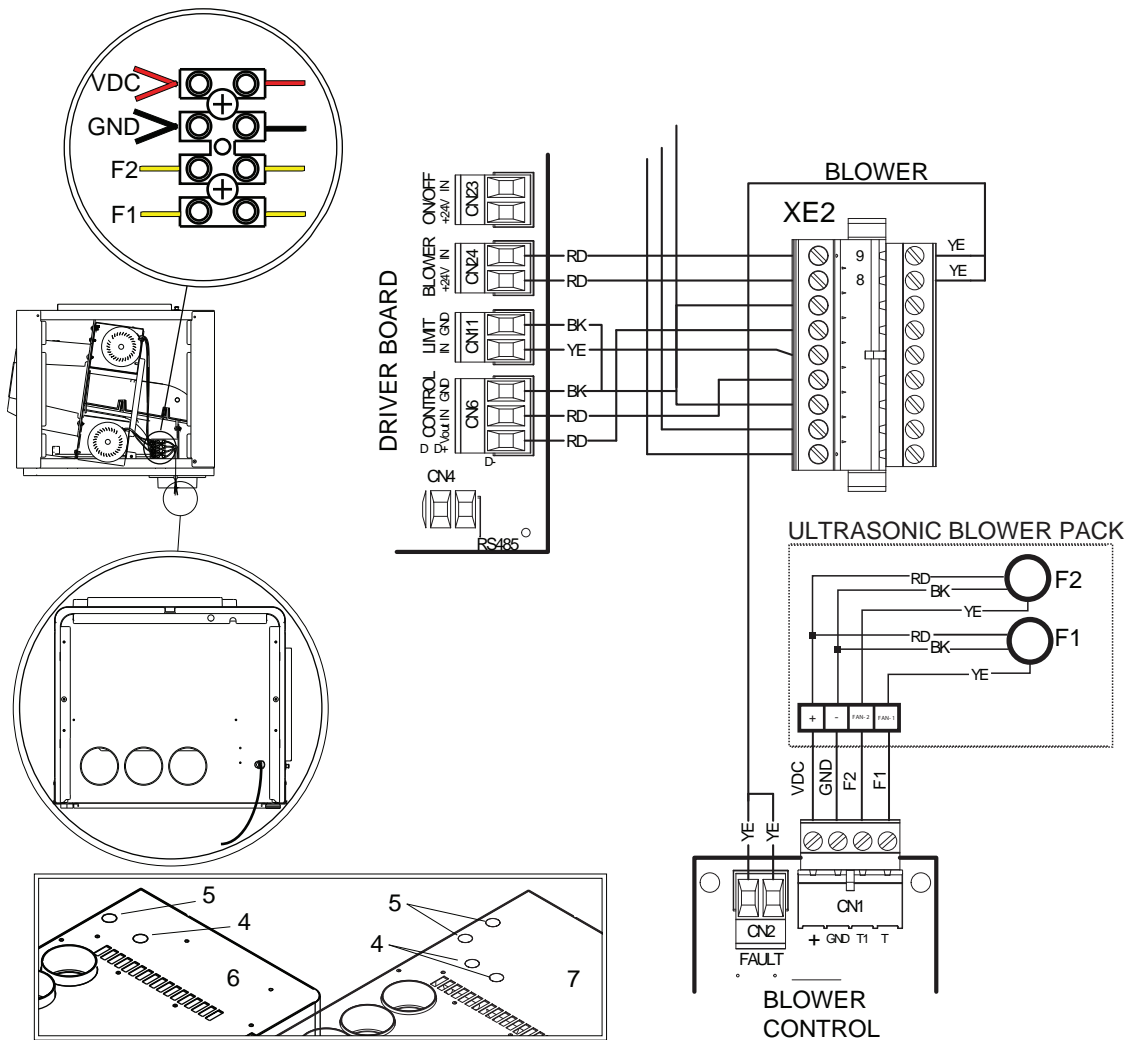

Figure 11 - Driver Board Connections

1. Control cabinet
2. External
3. Driver board
4. Knockout for wires
5. Knockout for control devices
6. Medium Ultrasonic Humidifier
7. Large Ultrasonic Humidifier

3. Fasten the Ultrasonic Blower Pack to the humidifier.

Ultrasonic Blower Pack units can only be direct-mounted on medium Ultrasonic Humidifier units. .

- a. Slowly lower the Ultrasonic Blower Pack and ensure that there are no kinks in any wiring.
- b. Align the Ultrasonic Blower Pack mist inlet with the ultrasonic humidifier mist outlet, and ensure that holes A (on the humidifier) and B (on the blower pack) are aligned, as shown in [Figure 12 on the next page](#).
- c. From the ceiling of the humidifier, fasten the Ultrasonic Blower Pack to the top of the humidifier with M4x6 mm screws (supplied). Refer to [Figure 12 on the next page](#). From inside the plumbing section of the humidifier, the Ultrasonic Blower Pack's mist channel should extend beyond the ceiling.

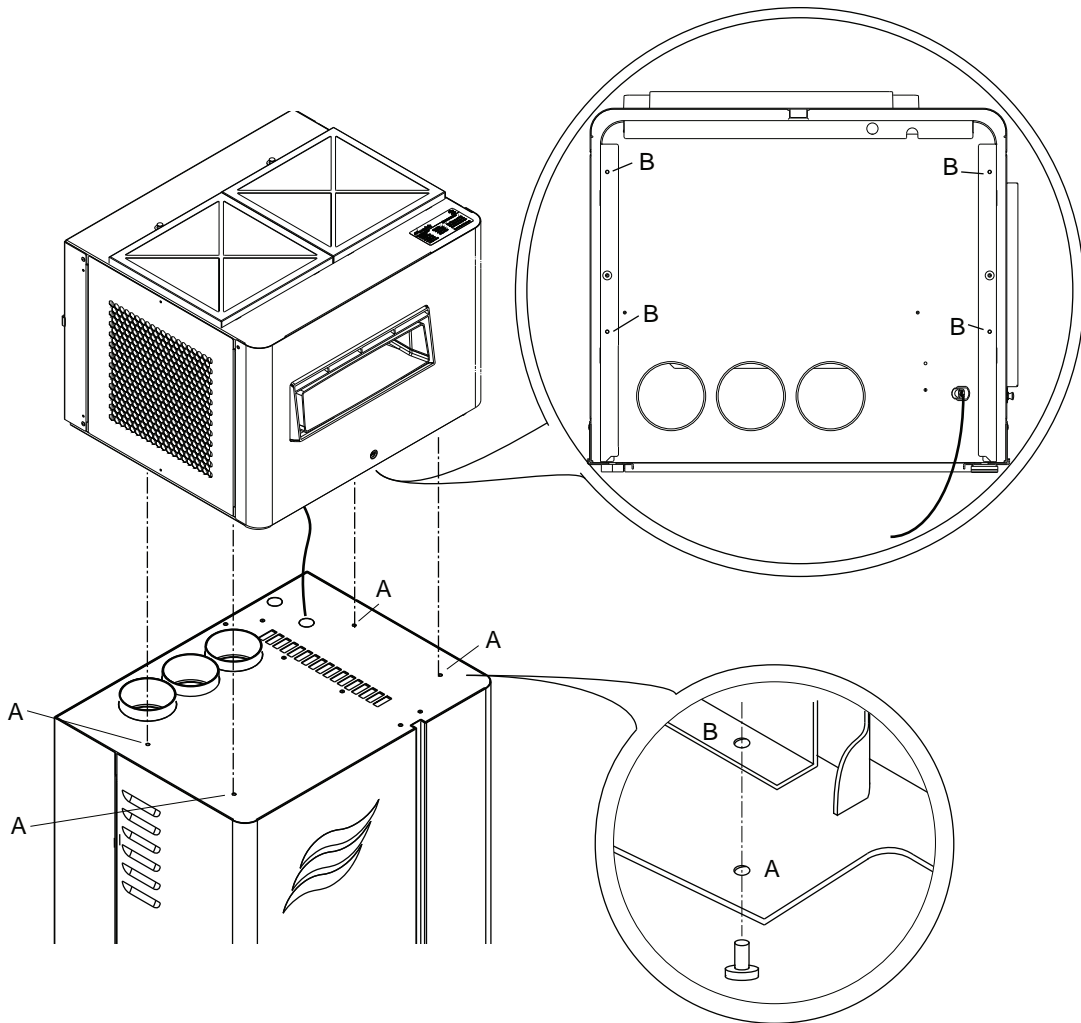

Figure 12 - Direct-mounting the Ultrasonic Blower Pack to the Humidifier

4. Connect the flexible tubes. Refer to "[Flexible Tube Requirements](#)" on page 21.

IMPORTANT! Use gloves and keep the system clean during installation.

- a. Remove the clamp from the flexible tube. This will allow the flexible tube to pass through the top of the humidifier cabinet.
- b. Route the 'connector' end (item 3) of the flexible tube to the top of the water reservoir. Secure the connection by gently inserting the connector and tube into the reservoir, as seen in [Figure 13 on the facing page](#).

If the Ultrasonic Blower Pack is directly mounted on the humidifier, the mist channel connection extends through the top of the humidifier, into the plumbing cabinet.

- c. Route the 'clamp' end (item 1) of the flexible tube through the top of the humidifier.
- d. Place the 'clamp' end (item 1) of the flexible tube over the base of the mist channel in the Ultrasonic Blower Pack. Ensure that there are no horizontal sections in the tube, then secure the connection by using clamps.
- e. Test the unit and check for leaks once installation is complete.

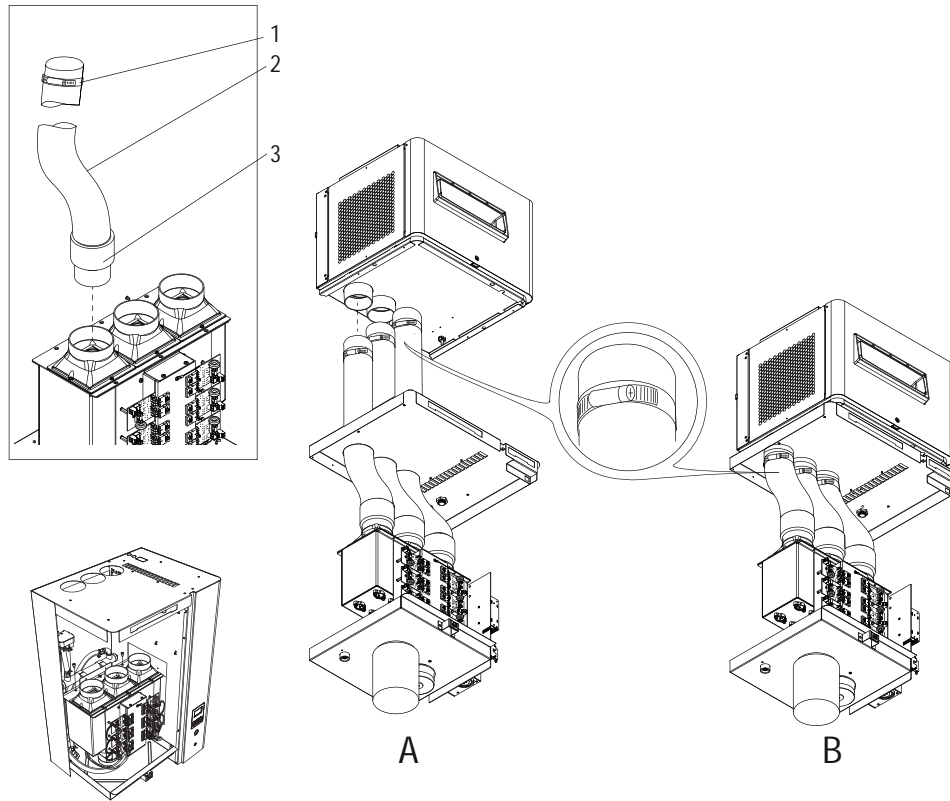

Figure 13 - Flexible Tubes. (A) Remote-Mount Installation. (B) Direct-Mount Installation.

1. Clamp
2. Flexible tube
3. Connector

5. Reinstall the door panels on the humidifier cabinet and control cabinet.
6. Perform the checks described in ["Installation Checklist" on page 45.](#)

8 Operation

8.1 General

Personnel Qualifications

The Ultrasonic Blower Pack must only be operated by personnel who are adequately qualified, competent, and are authorized by the customer.

Safety

Observe the following safety precautions.

8.2 Starting Up

The Ultrasonic Blower Pack is powered through the Ultrasonic Humidifier. Once the Ultrasonic Blower Pack is installed, the humidifier must be configured to recognize and control the unit. Refer to the Ultrasonic Humidifier Operation and Maintenance Manual.

IMPORTANT! Clean and disinfect the unit if the unit has been unpowered for an extended period of time (over 48 hours). Refer to "[Cleaning and Disinfecting](#)" on page 34.

8.3 Shutting Down the Unit

The Ultrasonic Blower Pack does not have an On/Off switch. The unit is directly powered by the humidifier. To shut down the Ultrasonic Blower Pack, shut down the Ultrasonic Humidifier.

Strictly observe all safety precautions and perform only the tasks described in this manual. Refer to "[For Your Safety](#)" on page 8.

IMPORTANT! Avoid unpowering your unit. To stop humidification, set your demand to 0. This will leave your unit powered and in 'standby' mode to allow your unit to flush regularly and prevent microbial growth.

To shut down the Ultrasonic Humidifier:

1. Shut off the water supply to the humidifier.
2. Make a note of the fault code, if any, displayed on the Home screen.
3. Set the On/Off button to the Off position.
4. Wait for the humidifier to drain the reservoir and shut down. The drain valve will remain open for 70 seconds to drain the unit. After this period, the drain valve will close.
5. Disconnect the power supply to the humidifier at the external disconnect switch. To prevent accidental power-up, lock out and tag out.

9 Maintenance

9.1 General

Strictly observe all safety precautions, and perform only those maintenance tasks described in this manual. Refer to ["For Your Safety" on page 8](#).

Use only original Condair replacement parts.

All maintenance work must be performed only by licensed personnel authorized by the customer. It is the customer's responsibility to verify qualifications of the personnel.

The maintenance work may require removal of the cover on the unit.

The Ultrasonic Humidifier may need to be unplugged to safely maintain and operate on the unit. Refrain from unpowering the unit (for more than 48 hours) unless it is deemed necessary, as unpowered units will not flush.

9.2 Cleaning and Disinfecting

Cleaning and disinfecting should be performed by authorized persons. Contact your Condair representative for more details.

Refer to ["Maintenance List" on page 36](#) for the general procedure and frequency of maintenance.

Disinfectants are mandatory, and must NOT produce toxic residue. Observe all safety precautions labeled on the disinfectants and cleaner.



CAUTION!

Risk of damage to the humidifier components!

Do NOT use solvents, aromatized, or halogenized hydrocarbons, or other harsh chemicals for cleaning.

Do NOT use cleaning materials that could leave scratches on wet, plastic and metal surfaces of the unit.

Do NOT use hard or metallic brushes to clean the unit.

Condair recommends the following:

- Avoid recontaminating the components. Use clean gloves (that are safe to use with the agents listed below) when handling components and cleaning agents.
- For cleaning: dish washing soap
- For descaling: citric acid solution

Note: pH 2, or 20g citric acid in 1 L water, or 0.18 lbs for every 1 gallon

- For disinfecting: 0.1% hydrogen peroxide, H₂O₂
- At the end of each cleaning, allow the humidifier to fill and create mist for 2-3 minutes, then perform a full drain cycle. This should be performed manually or through changing the demand signal (full demand to mist; zero stop mist and allow to drain).

Condair provides a cleaning and disinfecting kit for the Ultrasonic Humidifier (P/N: 2594996)

IMPORTANT! Avoid cleaning with hard or rough materials, such as steel wool, or metal brushes. Abrasions on the surface of any components may prevent micro-organisms from being cleaned easily. Instead use a clean cloth or soft brush.

Avoid materials that will leave particles behind.

Avoid using a hard, or metal (or otherwise abrasive) brush.

To disinfect a component:

1. Review the maintenance instructions for the component that will be cleaned and disinfected. Specific considerations must be taken into account for some components.
2. Ensure UV assembly is shut down before disinfection.
3. Clean the component with hot water and soap, and rinse with water. Remove biofilms and any surface impurities. Avoid using hard or metallic brushes (to avoid surface abrasions) to clean and disinfect.
4. Descale components using citric acid* (pH 2), then rinse with water.
 - *Let the component soak for 20 minutes and avoid scrubbing. Do NOT agitate the piezoelectric transducers because they are very fragile.
5. Apply disinfecting agent (0.1% hydrogen peroxide) to the component and allow to air dry (this allows the agent to penetrate and kill pathogens).
6. Rinse thoroughly with **clean** water (RO or DI water) to remove residue.

To disinfect hoses:

1. Clean and disinfect hose connections, as described above.
2. Remove any residue or particles from the hoses.
3. Flush the hoses with hot water.
4. Flush the hoses with disinfecting liquid and allow to air dry.
5. Rinse the hoses with **clean** water (RO or DI water) to remove residue from disinfectant.

9.2.1 Diluting your Disinfecting Solution (H₂O₂) to 0.1%

A 0.1% hydrogen peroxide solution is recommended to disinfect the unit. If a 0.1% solution is not readily available, you may need to dilute your current solution.

General Formula

Before mixing your solutions, you should know the following:

- The desired concentration of disinfectant (Hydrogen Peroxide) in the mixture (0.1%).
- The current concentration of the disinfectant (Halomist is 5% Hydrogen Peroxide).

If the total volume of the required final mixture is known:

1. Calculate the required volume of concentrated disinfectant

$$\text{Required Volume of Concentrated Disinfectant} = [\text{Desired Volume of Mixture}] \times \frac{[\text{Desired Concentration of Mixture}] \%}{[\text{Concentration of Disinfectant}] \%}$$

2. Calculate the required volume of fresh water

$$\text{Required Volume of Fresh Water} = [\text{Desired Volume of Mixture}] - [\text{Required Volume of Concentrated Disinfectant}]$$

It may be easier to submerge some components of the unit into the disinfecting solution, or the volume of the diluted solution may not be known (i.e. fresh water has already been secured).

If the total volume of the required final mixture is NOT known, but volume of fresh water is known:

1. Calculate the required volume of concentrated disinfectant

$$\text{Required Volume of Concentrated Disinfectant} = \frac{\text{[Volume of Fresh Water]} \times \text{[Desired Concentration of Mixture]\%}}{\text{[Concentration of Disinfectant]\%} - \text{[Desired Concentration of Mixture]\%}}$$

Table 6: Volume of water and H₂O₂ required for 0.1% hydrogen peroxide solution.

Desired concentration of Hydrogen Peroxide: 0.1%				
Desired volume of diluted solution (0.1% hydrogen peroxide)	Volume Units to Mix to Produce 0.1% Hydrogen Peroxide			
	Water	Halomist, H ₂ O ₂ (5%)	Water	H ₂ O ₂ (3%)
1 unit	0.98	0.02	0.967	0.033
2 units	1.96	0.04	1.933	0.067
3 units	2.94	0.06	2.900	0.100
4 units	3.92	0.08	3.867	0.133
5 units	4.90	0.10	4.833	0.167
6 units	5.88	0.12	5.8	0.2
7 units	6.86	0.14	6.767	0.233
10 units	9.80	0.20	9.667	0.333
30 units	29.40	0.60	29.00	1.00
50 units	49.00	1.00	48.333	1.667

9.3 Maintenance List

Perform the following maintenance tasks at the intervals specified in [Table 7 on the next page](#). For the components referenced in the table, refer to "[Spare Parts List: Ultrasonic Blower](#)" on page 40.

Table 7: Maintenance List

Task/Component	Frequency	Description
Check for water leaks	Weekly	Check the humidifier and blower pack for water leaks, stains and calcium deposits. If present, identify the source of the leak and tighten or replace components, as required.
Vacuum dust	Weekly	Vacuum the dust from the top of the Ultrasonic Blower Pack including the optional filter (if installed). Dust accumulation can affect performance of the unit.
Replace or clean air filter element	Weekly-Monthly	Clean or replace all air filters for air leading to the humidifier and Ultrasonic Blower Pack. Refer to the specific cleaning/replacement instructions packaged with the air filters.
Check for loose wiring	Annually	Visually inspect external electrical wiring for loose connections or damage to the wiring. Repair as appropriate.
Clean the mist channel	Weekly-Monthly	Use a wet, non-abrasive cloth to remove any scale, dust or debris that may have accumulated at the outlet of the distributor assembly. If results from inspections are satisfactory (as per your risk assessor), mist channel may be cleaned monthly. Remove any dust and debris.
Clean the flexible tubes	Weekly-Monthly	Use a wet, non-abrasive cloth to remove any scale, dust, or debris that may have accumulated on and inside the flexible tubes. If results from inspections are satisfactory (as per your risk assessor), flexible tubes may be cleaned monthly.
Clean the fans	Weekly-Monthly	Visually inspect the fans for a faulty connection or damage. Repair or replace as appropriate. Clean the fans of any accumulated dust. If results from inspections are satisfactory (as per your risk assessor), fans may be cleaned monthly. Remove any dust and debris.

10 Troubleshooting

Troubleshooting of the Ultrasonic Blower Pack must only be performed by qualified and competent personnel. Electrical repairs must only be performed by a licensed electrician authorized by the customer, or by Condair service technicians.

Troubleshooting the Ultrasonic Blower Pack may require the user to access the inside of the unit, to the control and plumbing cabinets, which may expose the user and equipment to hazards described in ["For Your Safety" on page 8](#).

10.1 General Troubleshooting

Most operation warning and fault conditions are caused by improper installation, or by not adhering to the suggested best practices for installation of the humidifier and system components. Hence, a full fault diagnosis always requires a thorough examination of the entire system (hose connections, control systems, etc.).

General guidelines for troubleshooting are described below. For detailed troubleshooting of auxiliary system components, refer to their respective manuals.

Ultrasonic Blower Pack fan(s) are not operating

Probable Cause

- No power to blower pack.
- Fan(s) damaged.

Corrective Action

- Check power connection.
- Check the fans for any damage or blockages.
- Make sure that the humidifier operates, and there is a demand for humidity.

Ultrasonic Blower Pack is making unusual noises while running

Probable Cause

- Improper assembly (ex. loose parts in the unit, replacement parts poorly installed, etc.).
- Blockage in front of the fans (in the unit).
- Blockage or dirty air intake filters.
- Damaged fan bearings.

Corrective Action

- Reassemble the Ultrasonic Blower Pack. Ensure any loose parts are secured.
- If there is a blockage, remove and inspect the pressurized box. Check for any debris or structures that may cause blockages or redirection of the air flow in and out of the fan.
- Check for blockages in the air intake filter. Blockages may be caused by excess dirt in the filter. Replace the filter(s).
- If the fan bearings are damaged, the fan(s) must be replaced.

Ultrasonic Blower Pack is spraying or dripping water

Probable Cause

- Ultrasonic Blower Pack is not level.
- Obstructed airflow from the pressurized box (may be caused by damage or blockage).
- Obstructed airflow or dirty surfaces in the mist channel.

Corrective Action

- Level the Ultrasonic Blower Pack with adjustable legs, or re-mount the unit.
- Inspect the fans and pressurized box. Remove any blockages or replace the pressurized box.
- Clean dirty surfaces and ensure that the surface is smooth and without blockages, especially at distances up to 70 mm (2.75 in) from the mist outlet.

11 Spare Parts List: Ultrasonic Blower

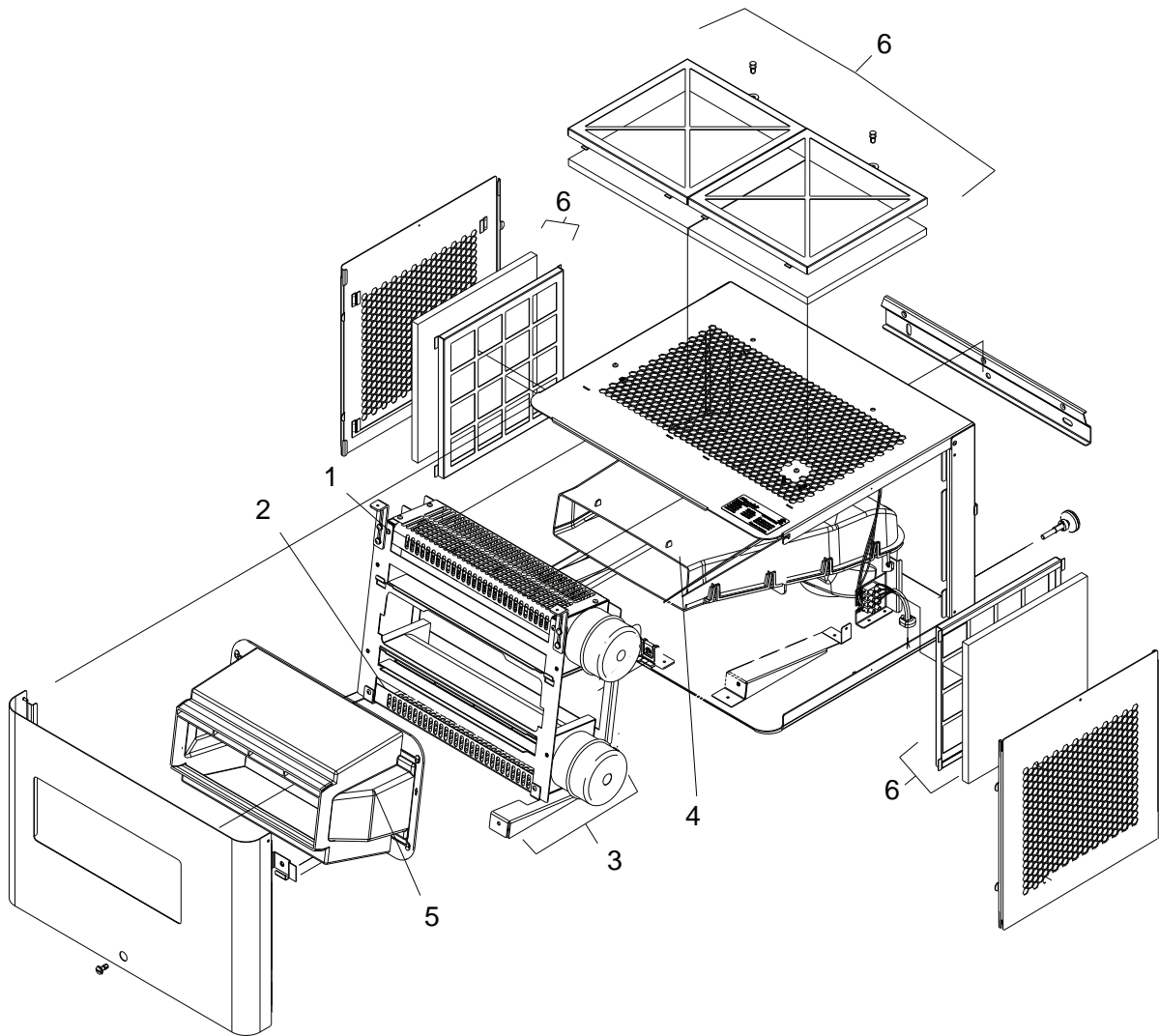

Figure 14 - Ultrasonic Blower Pack Spare Parts. Refer to [Table 8 on the next page](#).

Table 8: Ultrasonic Blower Pack Spare Parts List

Item	Part Number	Description	Quantity
1	2588752	SP, Fan 1, BP, US Humidifier Set includes: <ul style="list-style-type: none"> Fan 1, left-turn (qty. 1) Screw, 3.5 MM (qty. 10) Distributor, box end foam (qty. 3) 	1
2	2588753	SP, Fan 2, NP, US Humidifier Set includes: <ul style="list-style-type: none"> Fan 2, right-turn (qty. 1) Screw, 3.5 MM (qty. 10) Distributor, box end foam (qty. 3) 	1
3	2588754	SP, Fan Assembly, BP, US Humidifier Set includes: <ul style="list-style-type: none"> Fan assembly (qty. 1) Screw, 3.5 MM (qty. 4) Screw, M4x10 (qty. 2) 	1
4	2588755	SP, Mist Channel, BP, UB-20 Set includes: <ul style="list-style-type: none"> Mist channel assembly, UB-20 (qty. 1) Screw, M4x10 (qty. 2) 	1
	2588757	SP, Mist Channel, BP, UB-13 Set includes: <ul style="list-style-type: none"> Mist channel assembly, UB-13 (qty. 1) Screw, M4x10 (qty. 2) 	1
	2588758	SP, Mist Channel, BP, UB-07 Set includes: <ul style="list-style-type: none"> Mist channel assembly, UB-07 (qty. 1) Screw, M4x10 (qty. 2) 	1
5	2588756	SP, Pressurized Box, BP, US Humidifier Set includes: <ul style="list-style-type: none"> Pressurized box (qty. 1) Screw, M4x10 (qty. 4) 	1
6	2588764	SP, Filter Set, BP, US Humidifier Set includes: <ul style="list-style-type: none"> Frame, filter (qty. 2) Foam, filter (qty. 4) Plunger, snap latch (qty. 2) Grommet, snap latch (qty. 2) Frame, filter side (qty. 2) 	1

12 Commissioning

12.1 General

The Ultrasonic Blower Pack must be commissioned and operated only by personnel who are adequately qualified and familiar with the Ultrasonic Blower Pack. It is the customer's responsibility to verify the qualifications of personnel.

12.2 First-time Commissioning

The unit must always be commissioned for the first time by a service technician from your Condair representative, or by personnel who are well trained and authorized by the customer. For this reason, this manual only provides an outline, and not the details of the commissioning protocol.

Outline:

1. Inspect the mounting of the unit.
2. Inspect the mist, water, and drain line installation.
3. Inspect the electrical installation.
4. Configure the Ultrasonic Blower Pack through the humidifier controls.
5. Conduct any applicable performance tests, including controls.
6. Fill out the commissioning protocol documents.

13 Decommissioning

13.1 General

If the Ultrasonic Blower Pack needs to be replaced or removed from service for disposal, strictly follow the instructions in this section.

Personnel Qualifications

All decommissioning work must be performed only by a qualified service technician authorized by the customer. It is the customer's responsibility to verify proper qualifications of the personnel.

Safety

The decommissioning work will require removal of the covers/door panels on the Ultrasonic Blower Pack.

Refer to ["For Your Safety" on page 8](#).

13.2 Removing Unit from Service

Remove the unit from service for disposal, or long-term storage, as follows. Use a qualified service technician.

1. Shut down the humidifier. Refer to ["Shutting Down the Unit" on page 33](#).
2. Disconnect the humidifier from the power source.
3. Disconnect the control signal inputs (including any power and security loop connections) from the terminal strips in the humidifier. Refer to [Appendix: "Wiring Diagram Ultrasonic Blower Pack" 1](#).
4. Remove the Ultrasonic Blower Pack from its mounting surface.
5. If the unit is to be put in long-term storage, store the unit in its original packaging inside a protected area. Refer to ["Receiving and Storage" on page 6](#).
6. If the unit is to be disposed, refer to ["Disposing or Recycling the Unit" below](#).

13.3 Disposing or Recycling the Unit

The Ultrasonic Blower Pack and its components must NOT be disposed in domestic waste, and should be brought to an authorized collection point. If required, dispose in accordance with local regulations at authorized collection facilities.

If you have any questions, please contact the appropriate local authorities, or your local Condaire representative.

APPENDIX

A Appendix:

Installation Checklist

Mounting

- Unit installed in a suitable location? Refer to "[Location Requirements](#)" on page 20.
- Unit installed with suitable clearances? Refer to "[Clearance Requirements](#)" on page 20.
- Mounting surface is stable and capable of supporting the full operating weight of the unit? Refer to "[Weights](#)" on page 16.
- Unit is level?
- Unit is fastened securely?

Flexible Tubes Connection

- Flexible tubes cleaned?
- The length of flexible tubes must be kept as short as possible
- Flexible tubes should allow condensate to flow back to the humidifier (otherwise, use condensate traps for drainage along the connection)
- The selected location for installation of the Ultrasonic Blower Pack should allow proper routing of the mist, as described in "[Remote Ultrasonic Blower Pack Installation](#)".

Electrical Connection

- Power supply meet the voltage and current requirements shown on the specification label? Refer to "[Model Designation](#)" on page 12.
- All cables fastened securely?
- All cables free of tension and pass through any applicable cable glands or grommets?
- All electrical connections meet applicable codes?
- Electrical installation meet the applicable national and local codes?
- All door panels closed and fastened securely

Notes:

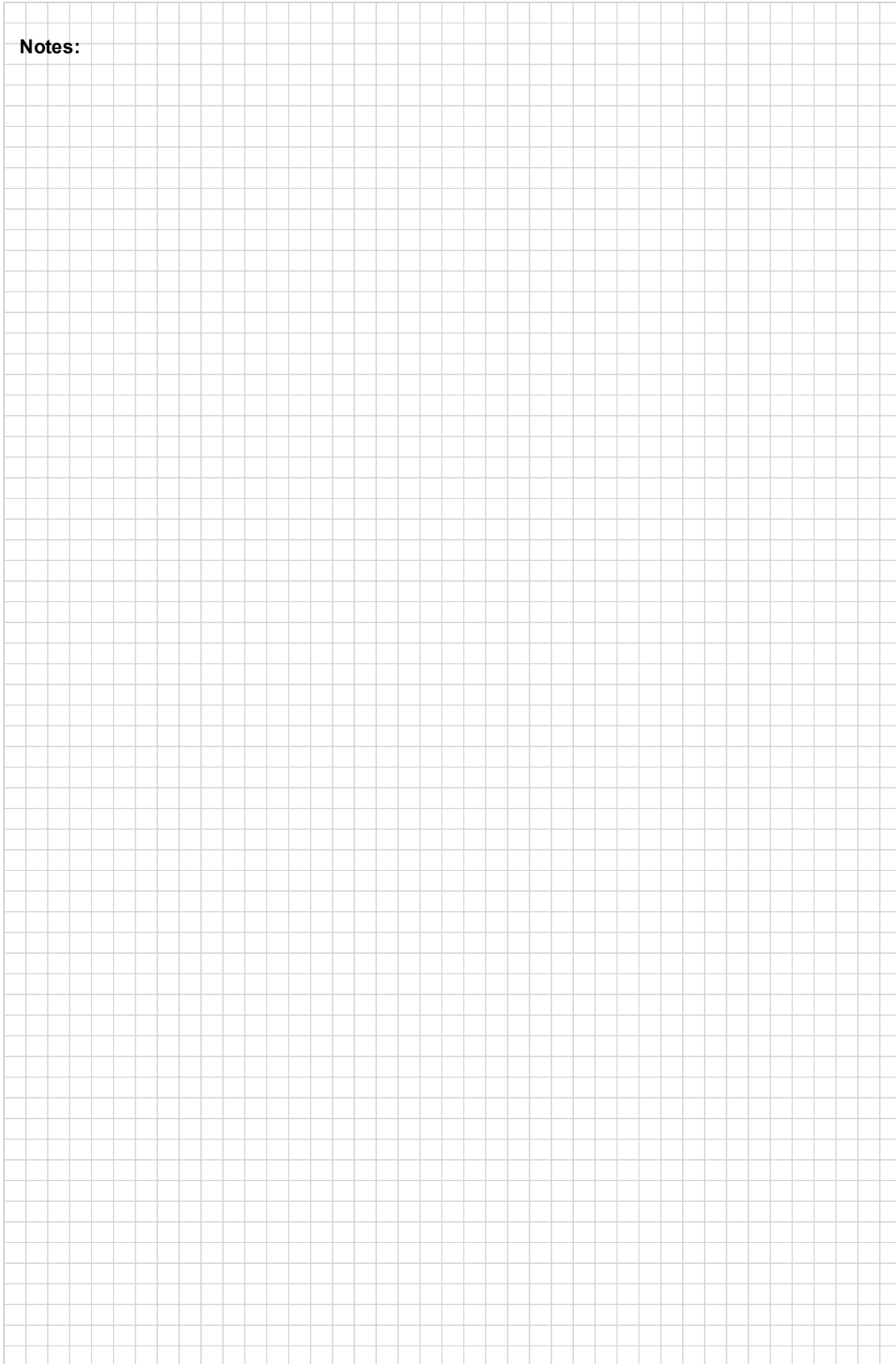

Warranty

Condair Inc. and/or Condair Ltd. (hereinafter collectively referred to as THE COMPANY), warrant for a period of two years after installation or 30 months from manufacturer's ship date, whichever date is earlier, that THE COMPANY's manufactured and assembled products, not otherwise expressly warranted, are free from defects in material and workmanship. No warranty is made against corrosion, deterioration, or suitability of substituted materials used as a result of compliance with government regulations.

THE COMPANY's obligations and liabilities under this warranty are limited to furnishing replacement parts to the customer, F.O.B. THE COMPANY's factory, providing the defective part(s) is returned freight prepaid by the customer. Parts used for repairs are warranted for the balance of the term of the warranty on the original humidifier or 90 days, whichever is longer.

The warranties set forth herein are in lieu of all other warranties expressed or implied by law. No liability whatsoever shall be attached to THE COMPANY until said products have been paid for in full and then said liability shall be limited to the original purchase price for the product. Any further warranty must be in writing, signed by an officer of THE COMPANY.

THE COMPANY's parts or materials that are considered consumables, including but not limited to: cylinders, filters, nozzles, membranes, media, gaskets, O-rings, etc. are NOT covered by the warranty.

THE COMPANY makes no warranty and assumes no liability unless the equipment is installed in strict accordance with a copy of the catalog and installation manual in effect at the date of purchase and by a contractor approved by THE COMPANY to install such equipment.

THE COMPANY makes no warranty and assumes no liability whatsoever for consequential damage or damage resulting directly from misapplication, incorrect sizing or lack of proper maintenance of the equipment.

THE COMPANY makes no warranty and assumes no liability whatsoever for damage resulting from freezing of the humidifier, supply lines, drain lines, or quality of the water used.

THE COMPANY retains the right to change the design, specification and performance criteria of its products without notice or obligation.

THE COMPANY's limited warranty on accessories, not of the companies manufacture, such as controls, humidistats, pumps, etc. is limited to the warranty of the original equipment manufacturer from date of original shipment of humidifier.

Extended Warranty

Extended warranties are available to purchase under the conditions listed above.



CONSULTING, SALES, AND SERVICE:

CANADA

2740 Fenton Road
Ottawa, ON, K1T 3T7

U.S.A.

835 Commerce Park Drive
Ogdensburg, NY 1366-2209

Tel: 1.866.667.8321

Fax: 613.822.7964

na.info@condair.com

www.condair.com

